

Optional item

Optional item	Model	
Basic items	Solid tyre	●
	No-marking solid tyre	○
	Two piece valve	●
	Three piece valve	○
	Standard forks	○
	Non standard forks and attachments	○
Safety items	Full set of OPS functions	●
	Safety protecting function of multiway valve overload	●
	Dry powder fire extinguisher (0.5kg)	○
	Dry powder fire extinguisher (2kg)	○
	Reverse buzzer	●
	Reverse Chinese voice speaker	○
	Central wide-angle rearview mirror	○
	Rearview mirrors on two sides and central wide-angle rearview mirror	○
	Start with key, and card swiping	●
	Key start	○
Comfort items	He' an seat	●
	Grammer seat	○
	Mechanical operated valve	●
	Fan	○
	LED rear work light (1 piece)	○
Lights	LED red/blue spotlight (1)	○
	Lateral and rear red/blue strip lights	○
	Fixed LED flashing warning lights	○
	Fixed LED rotary warning light (K2C11LI-S is optional)	○
	Fixed LED rotating buzzer warning light	○
	HELI Lithium Battery	●
Others	CATL Lithium Battery	○
	EIKTO Lithium Battery	○
	HELI packaging	●
	Without HELI packaging	○
	Chinese plates	●
	English plates	○
Customized special language plates	○	

Note: "●" standard ; "○" optional ;

CPD 08/10/12 SQ

A1H4/A5H4/A1LIH4/A5LIH4

H4 SERIES



0.8-1.2 t

H4 Series Three Wheel Battery Powered Counterbalance Forklift Truck



ANHUI HELI CO., LTD.

Add / No.668, FangXing Road, Hefei, China

Fax / +86-551-63639966

Tel / +86-551-63639068(America); 63639258(Europe);
63639358(Asia); 63662105(Africa & Middle East)



LinkedIn



YouTube



Facebook

* Our products are subject to improvements and changes without notice.

Compact & Flexible

Durable & Excellent



Exquisite appearance
excellent performance



The truck has small size and small turning radius which is suitable for working in narrow spaces;
The truck has a light weight and is more suitable for floor work.

Comfortable space and
thoughtful operation



The truck has excellent driving space and easy access to operation controls.

Safe and reliable
convenient maintenance



Reliable and stable performance makes maintenance easier.

Exquisite Appearance Excellent Performance

The truck has small size and small turning radius which is suitable for working in narrow spaces; The truck has a light weight and is more suitable for floor work.



The Truck Has Small Turning Radius
And Good Passing Performance.

Foldable fork for elevator access is optional.



Front axle drive offers excellent performance.



Comfortable Space And Thoughtful Operation

The truck has excellent driving space and easy access to operation controls.

Wide view mast design offers wide view.

E — Economic
S — Energy Saving } Two adjustable driving modes

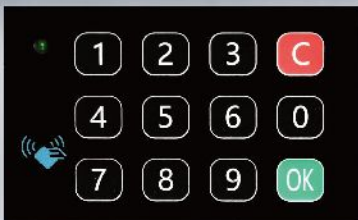

Card swiping starting is standard configuration for the truck.

The truck has large cab space with spacious legroom and headroom.

Ratchet type hand brake offers powerful operation.



Adjustable steering wheel angle is labor-saving and meets different needs.



Right mounted control valve stem offers easy operation.

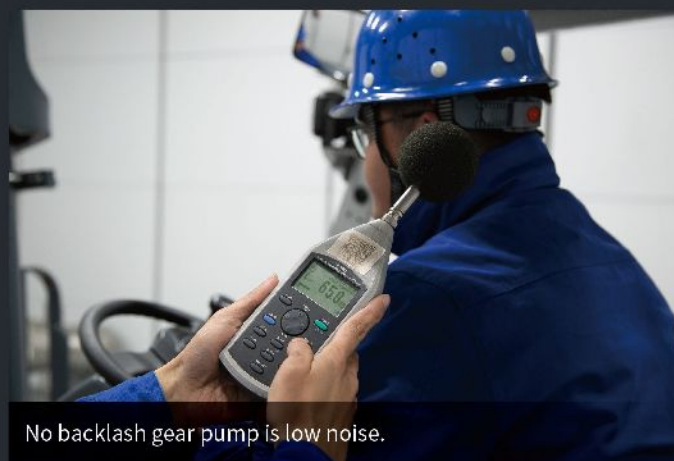

No backlash gear pump is low noise.

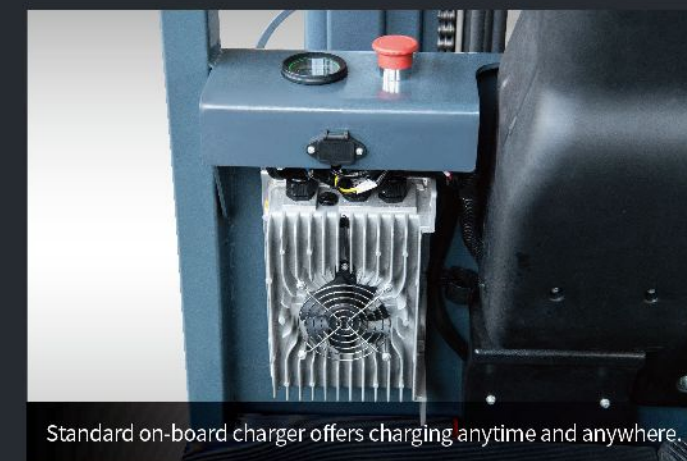

Standard on-board charger offers charging anytime and anywhere.

Safe And Reliable, Convenient Maintenance

Reliable and stable performance makes maintenance easier.

Reliable Components

Lights

The entire truck is equipped with a standard LED lighting system, which has high brightness, long service life, and is more energy-efficient.

Mast

High-strength H-shaped channel steel is adopted.

- Mast lowering buffer
- Hydraulic burst protection, forward tilting self-locking protection
- Electrical multiple protection: Short circuit protection, overheat protection, low power protection
- Parking safety reminder
- Slope sliding speed limit control
- Driver Presence Sensing System (Unmanned self-locking intelligent protection)、Operation sequence protection

- Detachable framework offers easy maintenance of electrical components;
- Integrated steering axle is durable;
- The drive motor can be disassembled separately which offers convenient maintenance;
- Common platform for lithium battery trucks and lead acid battery truck which offers high degree of universality of components.

The three electrical systems are mature and reliable.

The truck is adopted with maintenance-free IP54 AC motor, well-known brand electronic control and battery.

Steering axle

High level transverse oil cylinder hydraulic steering axle is adopted.

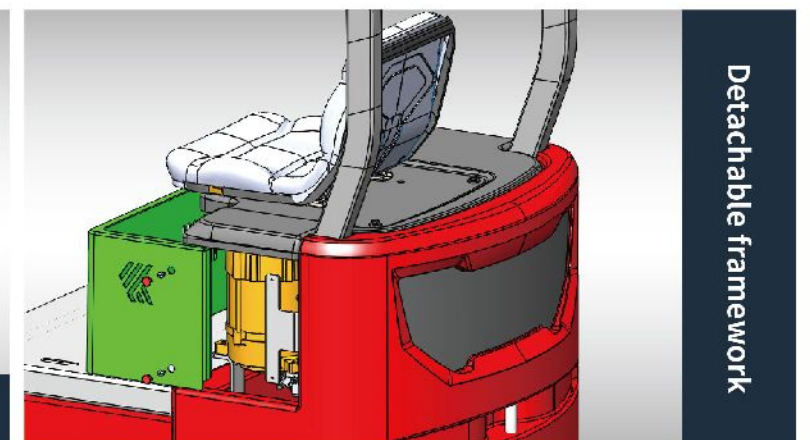
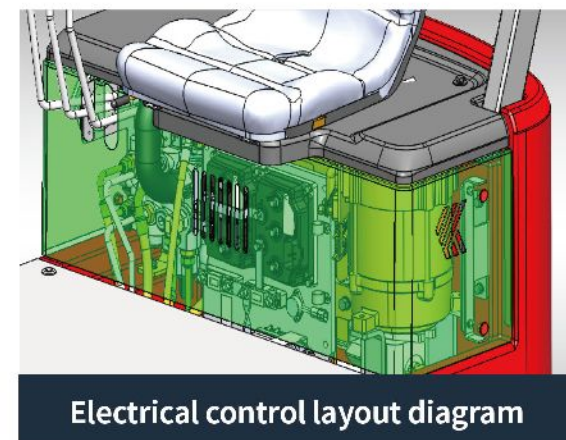
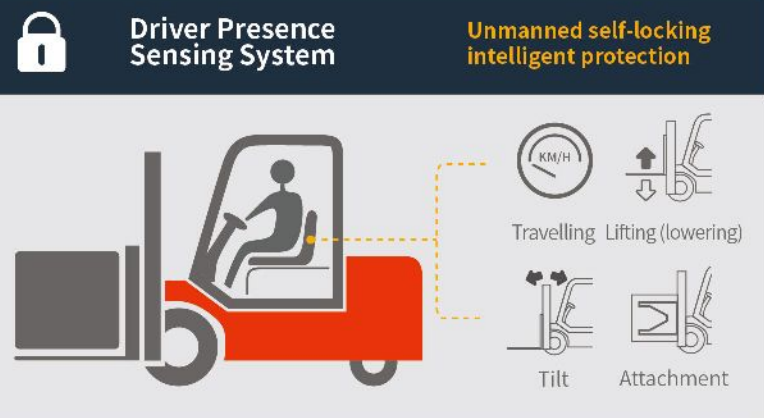
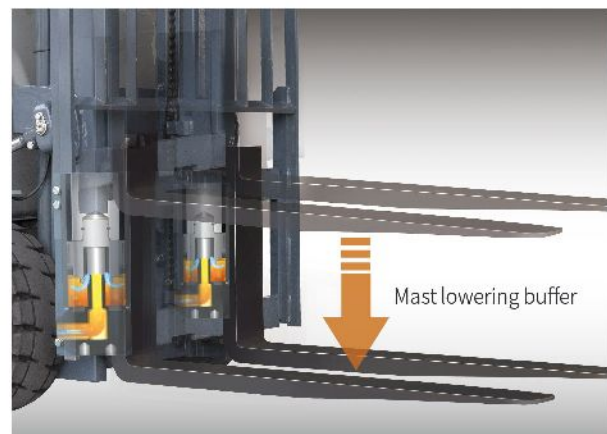

Detachable framework

Manufacturer and Technical Data									
HELI									
1.01	Manufacturer								
1.02	Model	CPD08SQ		CPD10SQ		CPD12SQ			
1.03	Configuration number	A1H4	A5H4	A1H4	A5H4	A1H4	A5H4	A1LH4	A5LH4
1.04	Rated capacity	800		1000		1200		400	
1.05	Load center distance	Q	kg						
1.06	Power mode	c	mm	Lead acid Battery			Lithium Battery		
1.07	Driving mode	Seated							
1.08	Front overhang	x	mm	305					
1.09	Wheelbase	y	mm	1150					
2.01	Total weight (with/without battery)	kg		1750/1557	1920/1655	2040/1740	1670/1555	1860/1745	1990/1870
2.02	Axle load (laden,front/rear)	kg		2210/340	2510/410	2850/390	2110/360	2430/430	2750/440
2.03	Axle load (unladen,front/rear)	kg		910/840	875/1045	890/1150	800/870	800/1060	810/1180
3.01	Tyre type	Solid tyre							
3.02	Tyre size,front	4.00-8							
3.03	Tyre size,rear	3.5-5							
3.04	Wheels,number front/rear (x=driven wheels)	2/2							
3.05	Tread, front	b10	mm	800					
3.06	Tread, rear	b11	mm	258					
4.01	Mast tilt angle (forward/backward)	a/β	°	5/7					
4.02	Height (mast lowered)	h1	mm	1975	1975	1975	1975	1975	1975
4.03	Free lifting height	h2	mm	60					
4.04	Lifting height (standard)	h3	mm	3000					
4.05	Max. height,extended (with backrest)	h4	mm	3800					
4.06	Height of overhead guard	h6	mm	1960					
4.07	Seat height relating to SIP (to ground)	h7	mm	1010					
4.08	Towing coupling height	h10	mm	425					
4.09	Overall length (with fork)	l1	mm	2440	2440	2460	2440	2460	2480
4.10	Overall length (without fork)	l2	mm	1670	1670	1690	1670	1690	1710
4.11	Overall width	b1	mm	900					
4.12	Fork size:thickness x width x length	s/e/l	mm	30×80×770					
4.13	Fork carriage,according to ISO2328	2A							
4.14	Distance across fork-arms, Max./Min.	b5	mm	800/180					
4.15	Distance across fork-arms, Max./Min.	m1	mm	65					
4.16	Ground clearance (center of wheelbase)	m2	mm	65					
4.17	Right angle stacking aisle width for pallet 800 x800mm	Ast	mm	2480	2480	2492	2480	2492	2508
4.18	Right angle stacking aisle width for pallet 1000 x1000mm	Ast	mm	2680	2680	2692	2680	2692	2708
4.19	Min. outside turning radius	Wa	mm	1480	1480	1492	1480	1492	1508
5.01	Travel speed (laden/unladen)	km/h 10/12							
5.02	Lift speed (laden/unladen)	mm/s		250/380	240/380	230/380	250/380	240/380	230/380
5.03	Lowering speed (laden/unladen)	mm/s 400/330							
5.04	Max.drawbar pull (laden/unladen)	N 3300/3800							
5.05	Max.gradeability (laden/unladen)	% 13/15 12/15 10/15 13/15 12/15 10/15							
5.06	Acceleration time(10 m)(laden/unladen)	s 6.7/6							
6.01	Battery voltage/Capacity (K5)	V/Ah		24/240	24/360	24/420	24/250	24/250	24/280
7.01	Driving motor powering (S2-60min)	kW 3.0							
7.02	Lifting motor powering (S3-15%)	kW 4.5							
7.03	Driving motor controlling mode	MOSFET/AC							
7.04	Lifting motor controlling mode	MOSFET/AC							
8.01	Service brake/Parking brake	Hydraulic/Mechanical							
8.02	Operating pressure for attachments	Mpa		14.5					

Lead acid Battery , Charger					
Voltage/Capacity(V/Ah)	24/240	24/300	24/360	24/420	24/480
CPD08SQ	●	○	-	-	-
CPD10SQ	-	-	●	○	○
COD12SQ	-	-	-	●	○
On-board charger	E24V35A-13C22			E24V50A-13C22	

Note: "●" standard ; "○" optional ; "-" non-configurable.

Lithium battery, Charger										
Lithium Battery brand	HELI			EIKTO			CATL			
Voltage/Capacity(V/Ah)	24/250	24/280	24/300	24/404	24/270	24/300	24/350	24/250	24/302	24/346
CPD08SQ	●	○	○	-	○	○	-	○	○	-
CPD10SQ	●	○	○	-	○	○	-	○	○	-
COD12SQ	○	●	○	○	○	○	○	○	○	○
Low temperature heating of lithium battery pack	●									
On-board charger	E24V50ALI-13C22									

Note: "●" standard ; "○" optional ; "-" non-configurable.

Mast parameters														
Mast type	Mast model	Max. lifting height (mm)	Load capacity (lode center 400mm)(kg)			Height (mast lowered) (mm)	Free lift (with backrest) (mm)	Service weight (kg)						Mast tilt angle α/β(°)
			0.8t	1.0t	1.2t			0.8t		1.0t		1.2t		
			0.8t	1.0t	1.2t	0.8-1.2t	0.8-1.2t	Lithium	Lead acid	Lithium	Lead acid	Lithium	Lead acid	
Wide View Standard Mast	M200	2000	800	1000	1200	1475	60	1617	1697	1807	1867	1937	1997	5°/7°
	M250	2500	800	1000	1200	1725	60	1644	1724	1834	1894	1964	2024	5°/7°
	M270	2700	800	1000	1200	1825	60	1654	1734	1844	1904	1974	2034	5°/7°
	M300	3000	800	1000	1200	1975	60	1670	1750	1860	1920	1990	2050	5°/7°
	M330	3300	800	1000	1200	2125	60	1686	1766	1876	1936	2006	2066	5°/7°
	M350	3500	800	1000	1150	2225	60	1696	1776	1886	1946	2016	2076	5°/7°
	M370	3700	750	900	1000	2325	60	1707	1787	1897	1957	2027	2087	5°/7°
	M400	4000	700	850	900	2525	60	1728	1808	1918	1978	2048	2108	5°/7°
	M425	4250	650	800	850	2675	60	1744	1824	1934	1994	2064	2124	5°/7°
	M450	4500	600	700	750	2825	60	1759	1839	1949	2009	2079	2139	5°/7°
Full Free 3-Stage Mast	ZSM360	3600	700	800	900	1695	820	1717	1797	1907	1967	2037	2097	5°/7°
	ZSM370	3700	650	750	850	1725	850	1722	1802	1912	1972	2042	2102	5°/7°
	ZSM400	4000	600	650	750	1825	950	1741	1821	1931	1991	2061	2121	5°/7°
	ZSM435	4350	500	550	650	1955	1080	1765	1845	1955	2015	2085	2145	5°/7°
ZSM450	4500	400	450	550	2005	1130	1774	1854	1964	2024	2094	2154	5°/7°	

Note: Wide View Full Free 3-Stage Mast:When there is no backrest, the free lifting height increases by 307.5mm.

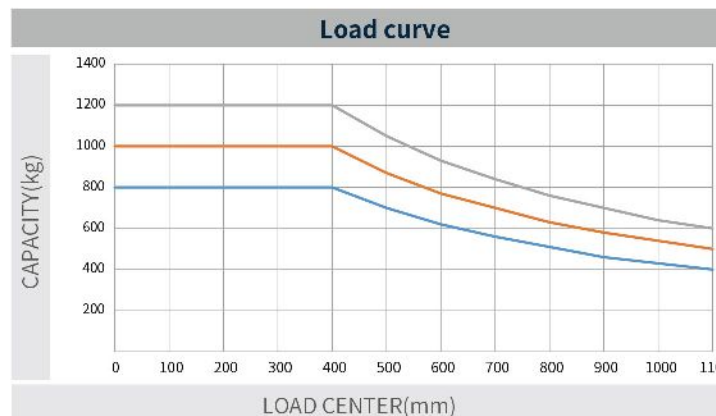
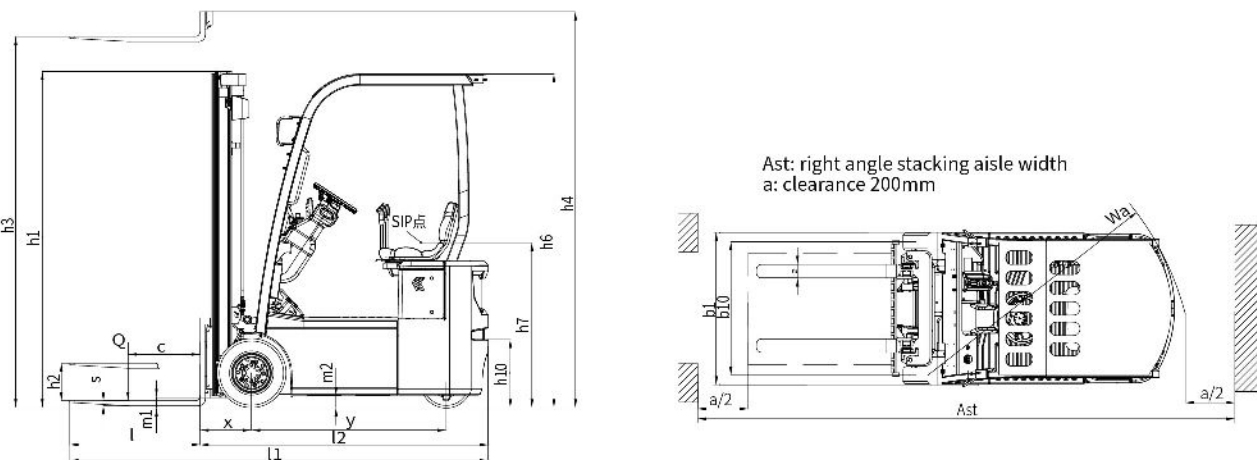

Note:
The vertical axis stands for load capacity and the horizontal axis stands for load center which is calculated from the front surface of the forks to the gravity of the standard load. The standard load means a cubic with 800mm edge length. When mast is tilted forward, using non-standard forks or loading large goods, the load capacity will be reduced. The load capacity of standard mast at different load center can be known from this load chart.